

SUN2000-(33KTL, 40KTL) Quick Installation Guide

Issue: 05
Part Number: 31507079
Date: 2015-11-21

HUAWEI TECHNOLOGIES CO., LTD.



NOTICE

1. The information in this document is subject to change without notice. Every effort has been made in the preparation of this document to ensure accuracy of the contents, but all statements, information, and recommendations in this document do not constitute a warranty of any kind, express or implied.
2. Before installing the device, read the *SUN2000-(33KTL, 40KTL) User Manual* for knowledge of product information and safety precautions. To obtain the user manual, log in to <http://support.huawei.com/carrier/> and browse or search for SUN2000 on the **Product Support** page.
3. Install and use the device according to this document and the user manual. Otherwise, the device may be damaged. Use insulated tools when installing the device.

Inverter Model	SUN2000-33KTL	SUN2000-40KTL
Weight	50 kg	
Dimensions (H x W x D)	770 mm x 550 mm x 270 mm	

1 System Installation

1.1 Determining the Installation Position (Unit: mm)

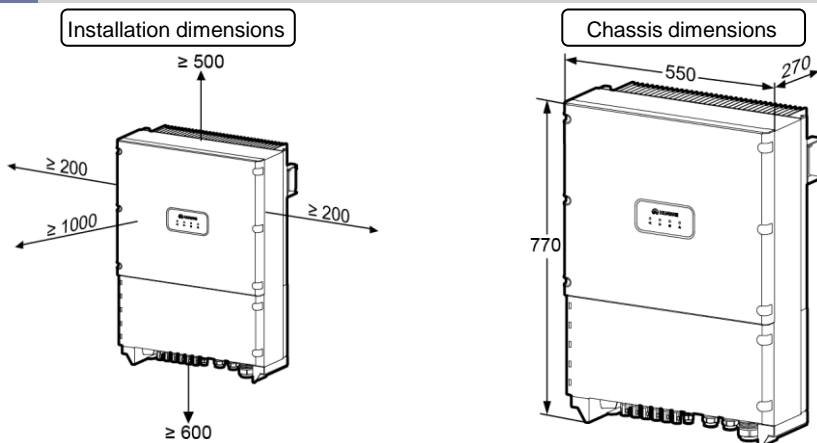

1.2 Determining the Installation Mode

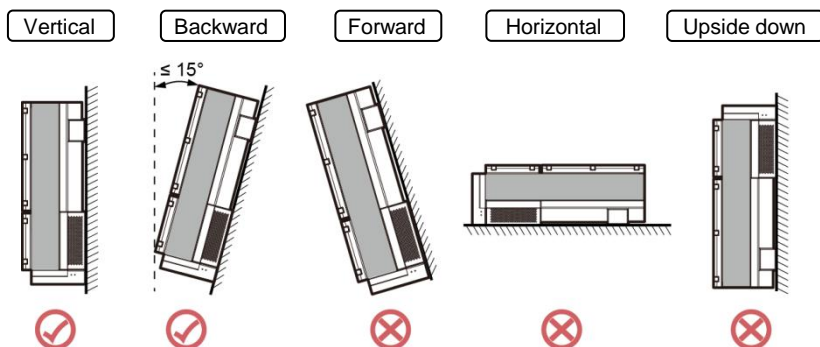

NOTE

In a vertical support, install the device vertically or with a backward tilt of no more than 15 degrees.

1.3 Installing an Inverter (Support-mounting Used as an Example)

1. Determine the hole positions on the support based on rear panel dimensions.

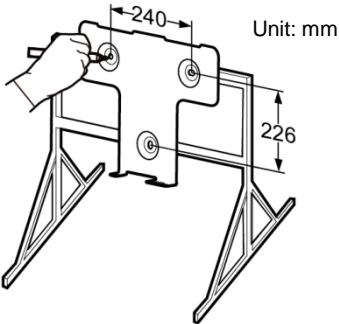

IS01HC0016

2. Drill holes.

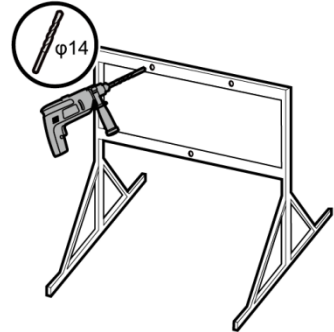

IS01HC0017

3. Secure the rear panel.

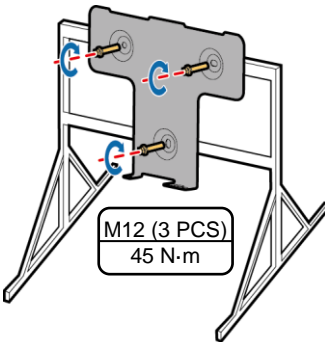

IS01HC0012

4. Mount the inverter on the rear panel.

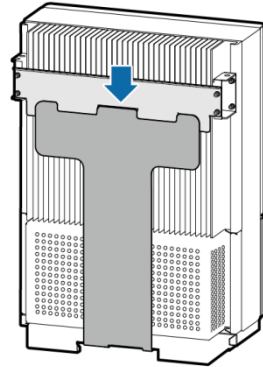

IS01HC0033

5. Tighten hexagon bolts.

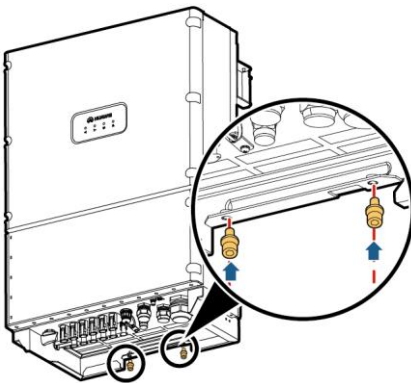

IS01HC0023

6. (Optional) Install an anti-theft lock.

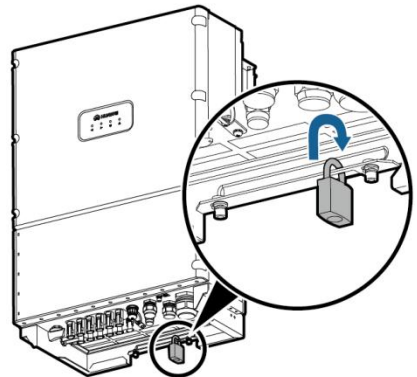

IS01HC0024



NOTE

1. The anti-theft lock is prepared by the customer.
2. For details about how to wall-mount the device, see the *SUN2000-(33KTL, 40KTL) User Manual*.

2 Electrical Connection

2.1 Installing a PGND Cable

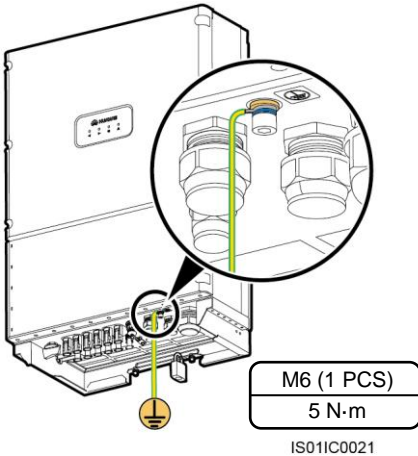

OT-M6



PE terminal

NOTE

1. It is recommended that an 8 mm² or 8 AWG outdoor copper-core cable be used as a ground cable. Ground cables must be securely connected.
2. It is recommended that the ground cable be connected to a nearby ground position. For a system with multiple inverters connected in parallel, connect the ground points of all inverters to ensure equipotential connections.
3. To prevent corrosion, apply silica gel or paint to the PE terminal after connecting the PGND cable.

2.2 Installing AC Output Power Cables

Inverter Model	Cable Type	Cross-sectional Area of the Cable (Recommended)
SUN2000-33KTL	4-core outdoor cable (L1, L2, L3, N)	16 mm ² or 6 AWG
SUN2000-40KTL	3-core outdoor cable (L1, L2, L3)	

NOTE

The table lists only the recommended cable specifications. For more information about cable specifications, see the *SUN2000-(33KTL, 40KTL) User Manual*.

1. Remove the two screws from the chassis door using a hex key and set them aside.

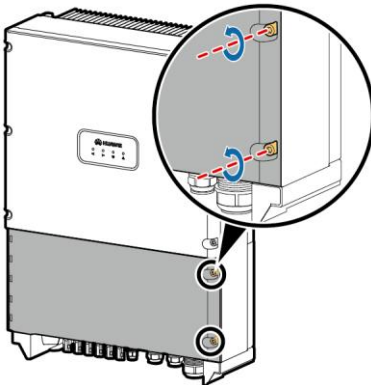

IS01HC0025

NOTICE

1. Do not open the door on the upper side of the inverter.
2. Before opening the chassis door, switch off the upstream DC input circuit breaker and downstream AC output circuit breaker.

- Open the chassis door and install the support rod available in the fitting bag bound to the reinforcing rib at the base of the chassis.

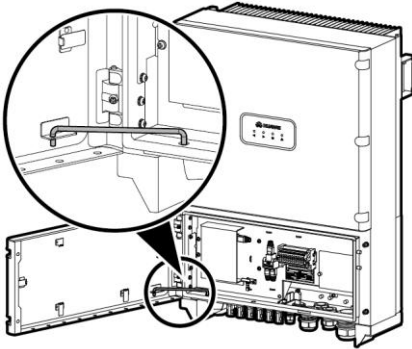

- Remove the AC terminal cover.

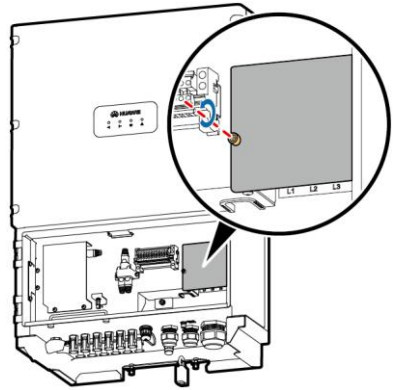

IS01HC0028

- Remove an appropriate length of the jacket and insulation layer from the AC output cable using a wire stripper.

- SUN2000-33KTL

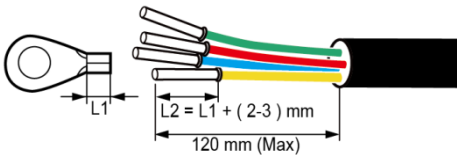

- SUN2000-40KTL

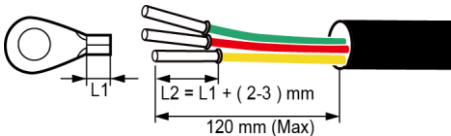

NOTE

The AC output power cable for the SUN2000-33KTL is a 4-core outdoor cable (L1, L2, L3, and N). The AC output power cable for the SUN2000-40KTL is a 3-core outdoor cable (L1, L2, and L3).

- Insert the exposed core wires into the crimp area of the OT terminal and crimp them using hydraulic pliers.
- Wrap the wire crimp area with heat shrink tubing or PVC insulation tape.



NOTE

If heat shrink tubing is used, put it through the power cable and then crimp the OT terminal.

- Remove the locking cap from the **AC OUTPUT** waterproof cable connector at the inverter bottom and remove the plug from the locking cap.
- Route the AC output power cable into the locking cap and the **AC OUTPUT** connector at the inverter bottom.

9. Connect the wires of the AC output cable for the SUN2000-33KTL to L1, L2, L3, and N on the AC terminal block. The required torque is 4 N·m. Connect the wires of the AC output cable for the SUN2000-40KTL to L1, L2, and L3 on the AC terminal block. The required torque is 8 N·m.

a. SUN2000-33KTL

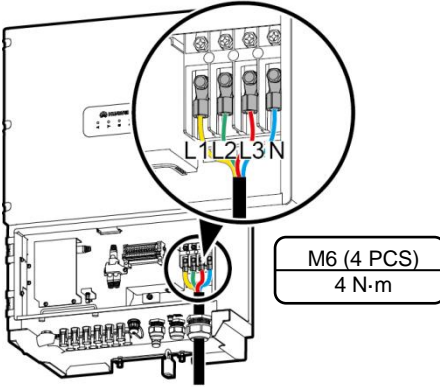

IS011C0023

b. SUN2000-40KTL

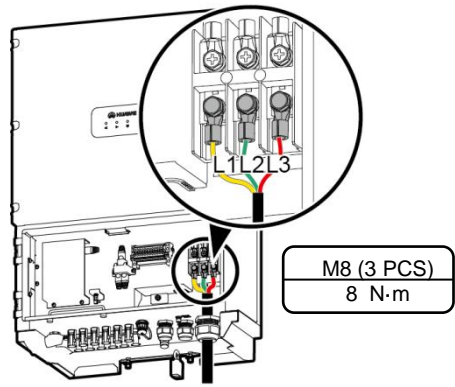

IS011C0029



NOTICE

Ensure that the AC output power cable is securely connected. Otherwise, the inverter may fail to run or the terminal block may be damaged after the inverter operates.

10. Use a torque wrench to tighten the locking cap to a torque of 7.5 N·m.

2.3 Installing DC Input Power Cables

Optional DC input terminals

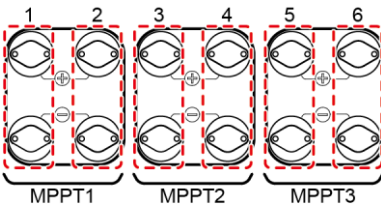

NOTE

Routes 1, 2, 3, 4, 5, and 6 are defined from left to right.

Number of Inputs	SUN2000-33KTL/40KTL
1	Connects to any one route
2	Connects to routes 1 and 3
3	Connects to routes 1, 3, and 5
4	Connects to routes 1, 2, 3, and 5
5	Connects to routes 1, 2, 3, 4, and 5
6	Connects to routes 1, 2, 3, 4, 5, and 6

Positive and negative metal terminals

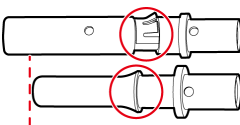

Positive metal terminal (female)

Negative metal terminal (male)

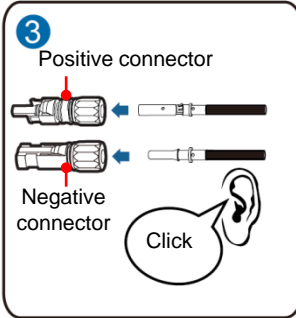
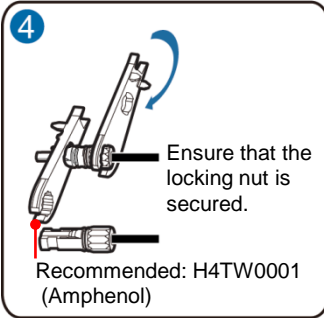
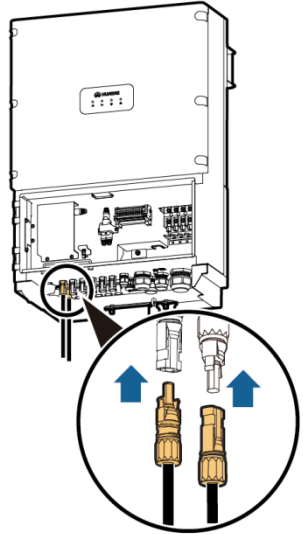
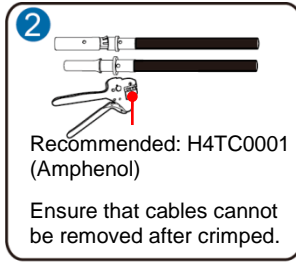
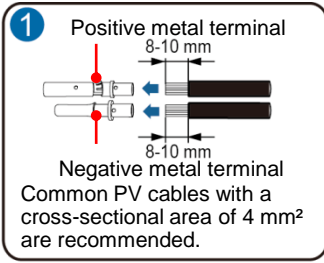

NOTICE

1. Before connecting DC input power cables, mark the polarities on the cables to ensure that the cables are connected correctly. If the cables are connected incorrectly, the device may be damaged.
2. Check that DC input power cables will not be disconnected by pulling them.
3. If DC input power cables are reversely connected and the DC switch is **ON**, do not turn off the **DC SWITCH** immediately. Otherwise, the equipment may be damaged. You can disconnect the DC input power cable on the PV string side or wait until the PV string voltage reduces to a value within the safety range. Then, turn off the **DC SWITCH**, remove the positive and negative connectors, and rectify the connection.

2.4 Selecting a Communication Mode

Model	Communication Mode		Remarks
	RS485	PLC	
SUN2000-33KTL (with PLC)	Supported	Supported	1. Only one communications mode can be selected in application scenarios. 2. If the PLC communications mode is selected, no device installation is required.
SUN2000-40KTL (with PLC)	Supported	Supported	
SUN2000-33KTL (without PLC)	Supported	Not supported	None.
SUN2000-40KTL (without PLC)	Supported	Not supported	None.

2.5 Installing RS485 Communications Cables

NOTICE

1. When routing communications cables, ensure that communications cables are separated from power cables and away from interfering source to prevent communication from being affected .
2. RS485 Communications cables can be connected to the terminal block or RJ45 ports. Connecting to the terminal block is recommended.

Method 1: Connecting to the Terminal Block (Recommended)

The DJYP2VP2-22 2*2*1 network cable or a communications cable with a cross sectional area of 1 mm² and external diameter of 14-18 mm is recommended.

1. Remove an appropriate length of the insulation layer from the cable using a wire stripper.

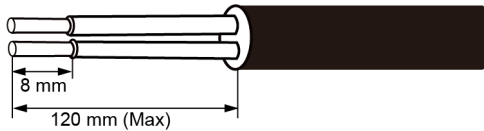

2. Remove the locking caps from the **COM1** and **COM2** waterproof cable connectors at the inverter bottom and remove the plugs from the locking caps.
3. Route the cables through the locking caps and the **COM1** and **COM2** connectors at the inverter bottom.
4. Connect the input end to terminals 5 and 7 in the terminal block and connect the output end to terminals 6 and 8 in the terminal block.
5. Bind the RS485 communications cables.

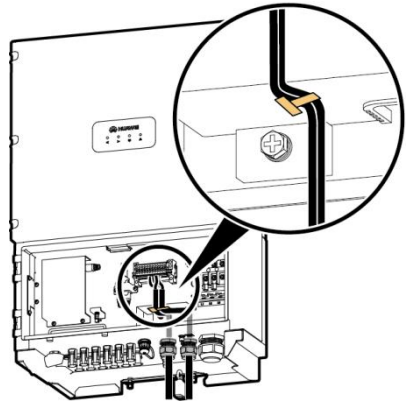
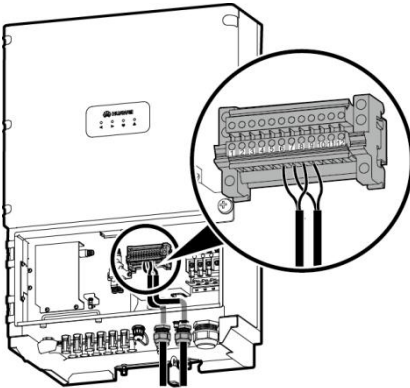

6. Use a torque wrench to tighten the locking caps to a torque of 7.5 N·m.

NOTE

To ensure good sealing, you are advised to apply firestop putty to the used waterproof cable connectors at the bottom of the chassis.

Method 2: Connecting to RJ45 Ports

Recommended outdoor network cable: cable outer diameter < 9 mm; internal resistance \leq 1.5 ohms/10 m.

1. Insert the wires of the network cable to the RJ45 connector in sequence.
2. Crimp the connectors using a crimping tool.

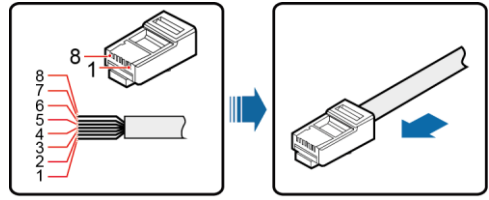

No.	Color	Pin Definition
1	White-orange	RS485A, RS485 differential signal +
2	Orange	RS485B, RS485 differential signal -
3	White-green	PGND
4	Blue	RS485A, RS485 differential signal +
5	White-blue	RS485B, RS485 differential signal -
6	Green	PGND
7	White-brown	PGND
8	Brown	PGND

3. Remove the locking cap from the **COM1** waterproof cable connector at the inverter bottom and remove the plug from the locking cap.
4. Route the cables through the locking cap and the **COM1** connector at the inverter bottom.
5. Connect the RJ45 connectors to the **RS485 IN** and **RS485 OUT** ports in the SUN2000 maintenance area.
6. Bind the RS485 communications cables.

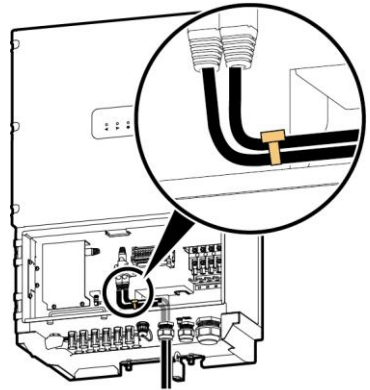
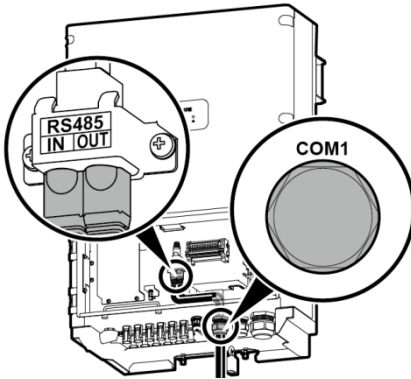

7. Use a torque wrench to tighten the locking cap to a torque of 7.5 N·m.



NOTE



1. Block the unused RS485 ports with waterproof plugs.
2. To ensure good sealing, you are advised to apply firestop putty to the used waterproof cable connectors at the bottom of the chassis.

3 Installation Verification

1. The SUN2000 is installed correctly and securely.	Yes <input type="checkbox"/> No <input type="checkbox"/>
2. All screws, especially the screws used for electrical connections, are tightened.	Yes <input type="checkbox"/> No <input type="checkbox"/>
3. All circuit breakers are switched to OFF.	Yes <input type="checkbox"/> No <input type="checkbox"/>
4. Ground cables are connected correctly and securely, with no open circuit or short-circuit.	Yes <input type="checkbox"/> No <input type="checkbox"/>
5. AC output power cables are connected correctly and securely, with no open circuit or short-circuit.	Yes <input type="checkbox"/> No <input type="checkbox"/>
6. DC input power cables are connected correctly and securely, with no open circuit or short-circuit.	Yes <input type="checkbox"/> No <input type="checkbox"/>
7. The DC input voltage is not higher than 1000 V and meets the local voltage range requirements.	Yes <input type="checkbox"/> No <input type="checkbox"/>
8. RS485 communications cables are connected correctly and securely.	Yes <input type="checkbox"/> No <input type="checkbox"/>
9. Idle DC input terminals are sealed.	Yes <input type="checkbox"/> No <input type="checkbox"/>
10. Idle USB and RS485 ports and waterproof connectors are plugged with waterproof plugs.	Yes <input type="checkbox"/> No <input type="checkbox"/>

4 System Power-on

1. Switch on the AC circuit breaker between the inverter and the power grid.
2. Set the **DC SWITCH** at the bottom of the inverter to **ON**.
3. (Optional) Measure the temperatures at the joints between the DC terminals and the connectors using a thermometer.
4. Observe the LED indicators to check the inverter operating status.

Indicator	Status	Meaning
PV connection indicator 	Steady green	At least one PV string is properly connected, and the DC voltage exceeds 200 V.
	Off	The inverter is disconnected from all PV strings.
Grid-tie indicator 	Steady green	The inverter is grid-tied.
	Off	The inverter is not grid-tied.
Communication indicator 	Blinking green (on for 0.5s and off for 0.5s)	The inverter is communicating properly.
	Off	The inverter has failed to communicate.

Indicator	Status	Meaning	
Alarm/ Maintenance indicator 	Alarm state	Blinking red slowly (on for 1s and then off for 4s)	The inverter has generated a warning.
		Blinking red fast (on for 0.5s and then off for 0.5s)	The inverter has generated a minor alarm.
		Steady red	The inverter has generated a major alarm.
	Local maintenance state	Blinking green slowly (on for 1s and then off for 1s)	Local maintenance is in progress.
		Blinking green fast (on for 0.125s and off for 0.125s)	Local maintenance has failed.
		Steady green	Local maintenance is successful.

5 SUN2000 APP



NOTE

1. The SUN2000 application is a mobile application that enables the SUN2000 to communicate with the SUN2000 monitoring system through a USB cable or Bluetooth module to query alarms, configure parameters, and perform routine maintenance. The mobile application is a convenient platform for monitoring and maintenance. The mobile application name is **SUN2000**.
2. Mobile operating system: Android 4.0 or later.
3. Access the Huawei app store (<http://appstore.huawei.com>) or Google Play (<https://play.google.com>), search for **SUN2000**, and download the SUN2000 APP software package.
4. The SUN2000 communicates with its mobile application through a USB cable or Bluetooth module connected over the USB port.

Login screen

Switch between users

Main menu

Quick settings

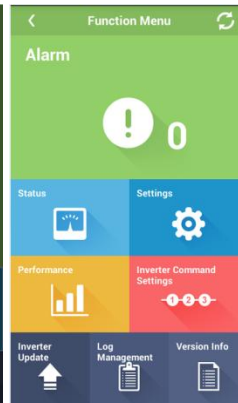
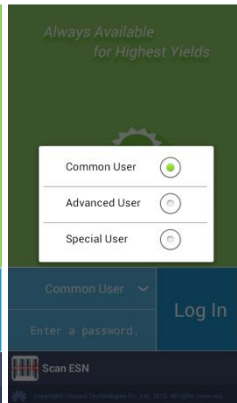
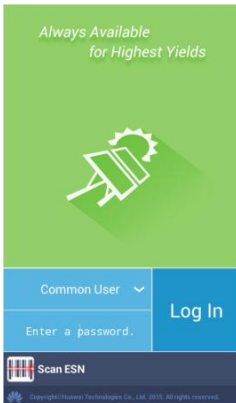



NOTICE

The initial password for **Common User**, **Advanced User**, and **Special User** is **000001** or **00000a**. Use the initial password to log in to the inverter for the first time and change the password immediately to ensure account security.



NOTE

1. Tap  to return to the login screen.
2. Inverter grid connection setup requires no parameter setting by default. The parameters can be adjusted based on site requirements. For parameter settings, see the *SUN2000-(33KTL, 40KTL) User Manual*.

Appendix 1: Power Grid Standard Code Mapping Table (SUN2000-33KTL)

No.	Power Grid Standard Code	Country and Condition	No.	Power Grid Standard Code	Country and Condition
1	NB/T 32004	China low-voltage power grid	2	VDE-AR-N-4105	Germany low-voltage power grid
3	EN50438-NL	Netherlands low-voltage power grid	4	BDEW-MV	Germany medium-voltage power grid
5	UTE C 15-712-1(A)	France low-voltage power grid	6	EN50438-CZ	Czech Republic low-voltage power grid
7	UTE C 15-712-1(B)	Islands of France 230 V 50 Hz	8	TAI-PEA	Thailand low-voltage power grid (PEA)
9	UTE C 15-712-1(C)	Islands of France 230 V 60 Hz	10	TAI-MEA	Thailand low-voltage power grid (MEA)
11	NRS-097-2-1	South Africa low-voltage power grid	12	VDE 0126-1-1-GR(A)	Mainland of Greece low-voltage power grid
13	KOREA	South Korea low-voltage power grid	14	VDE 0126-1-1-GR(B)	Islands of Greece low-voltage power grid
15	G59-England	England 230 V power grid (I > 16 A)	16	RD1699	Spanish low-voltage power grid (Pn < 100 kW)
17	G59-Scotland	Scotland 240 V power grid (I > 16 A)	18	RD661	Spanish low-voltage power grid (Pn > 100 kW)
19	G83-England	England 230 V power grid (I < 16 A)	20	VDE 0126-1-1-BU	Bulgaria low-voltage power grid
21	G83-Scotland	Scotland 240 V power grid (I < 16 A)	22	AS4777	Australia low-voltage power grid
23	CEI0-21	Italian low-voltage power grid	24	EN50438-TR	Turkey low-voltage power grid
25	CEI0-16	Italian medium-voltage power grid	26	C10/11	Belgium low-voltage power grid
27	Philippines	Philippines low-voltage power grid	28	Custom(60Hz)	Reserved
29	IEC61727	IEC low-voltage power grid	30	Custom(50Hz)	Reserved
31	IEC61727-60Hz	IEC low-voltage power grid (60 Hz)			

Appendix 2: Power Grid Standard Code Mapping Table (SUN2000-40KTL)

No.	Power Grid Standard Code	Country and Condition	No.	Power Grid Standard Code	Country and Condition
1	CHINA-MV480	China medium-voltage power grid	2	Philippines-MV480	Philippines medium-voltage power grid
3	EN50438-TR-MV480	Turkey medium-voltage power grid	4	BDEW-MV480	Germany medium-voltage power grid
5	UTE C 15-712-1-MV480	France medium-voltage power grid	6	G59-England-MV480	UK 480 V Medium-voltage power grid (I > 16 A)
7	Japan(50Hz)	Japan power grid (50 Hz)	8	TAI-PEA-MV480	Thailand medium-voltage power grid (PEA)
9	Japan(60Hz)	Japan power grid (60 Hz)	10	TAI-MEA-MV480	Thailand medium-voltage power grid (MEA)
11	NRS-097-2-1-MV480	South Africa medium-voltage power grid	12	AS4777-MV480	Australia medium-voltage power grid
13	IEC61727-MV480	IEC medium-voltage power grid(50 Hz)	14	EN50438-DK	Denmark medium-voltage power grid
15	IEC61727-60Hz-MV480	IEC medium-voltage power grid(60 Hz)	16	C11/C10-MV480	Belgium medium-voltage power grid
17	Custom-MV480(50Hz)	Reserved	18	Custom-MV480(60Hz)	Reserved



NOTE

Grid codes are subject to change. The listed codes are for your reference only.

For more information, refer to the channels provided on the following page.

Scan here for technical support (carrier):

Apple Store



Google Play



Huawei App Store



Scan here for more documents:

Support



WeChat



**You can also log in to Huawei technical support website:
<http://support.huawei.com>**

Huawei Technologies Co., Ltd.

Huawei Industrial Base, Bantian, Longgang
Shenzhen 518129 People's Republic of China
www.huawei.com